

**▼ Theory:**

The repeller unit is effective at repelling rodent pest, by emitting a sonic pulse as a vibration transmitted through the ground. Rodents then perceive a danger zone causing them to evacuate the area.

**▼ Repel:**

Rodent, mole, rat, gopher

**▼ Specification:**

1. Solar panel
2. Built-in "AA" Ni-Cd/Ni-MH rechargeable batteries
3. Frequency 400HZ
4. Effective on Moles, Voles, Gophers, Ground hogs and other Rodents
5. Transmits sonic wave every 30 seconds
6. Covers up to 625 square meter
7. With On/Off Switch
8. Material: ABS plastic

**▼ Application:**

Farm, Garden, Park, Lawn, Yard, etc.

**▼ Advantage:**

1. Use solar energy, eco-friendly.
2. Wireless and convenience in using
3. Working time not less than 8 hours when fully charged.
4. Waterproof

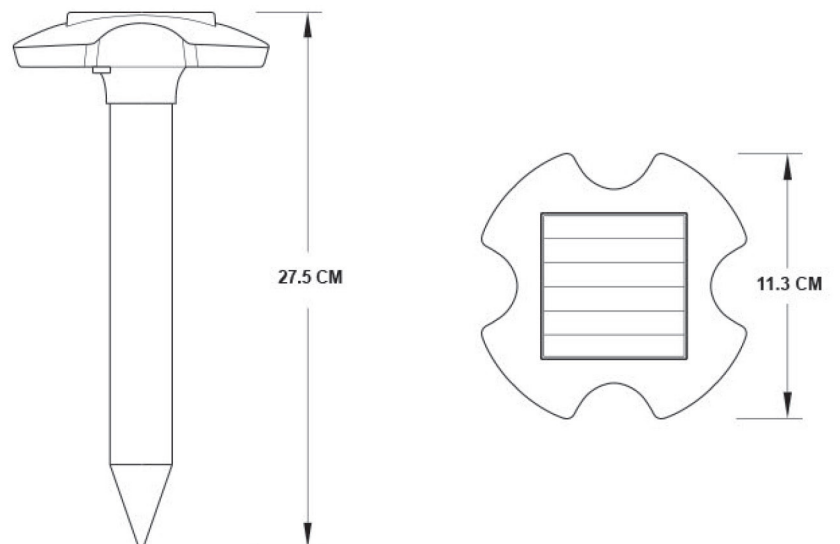

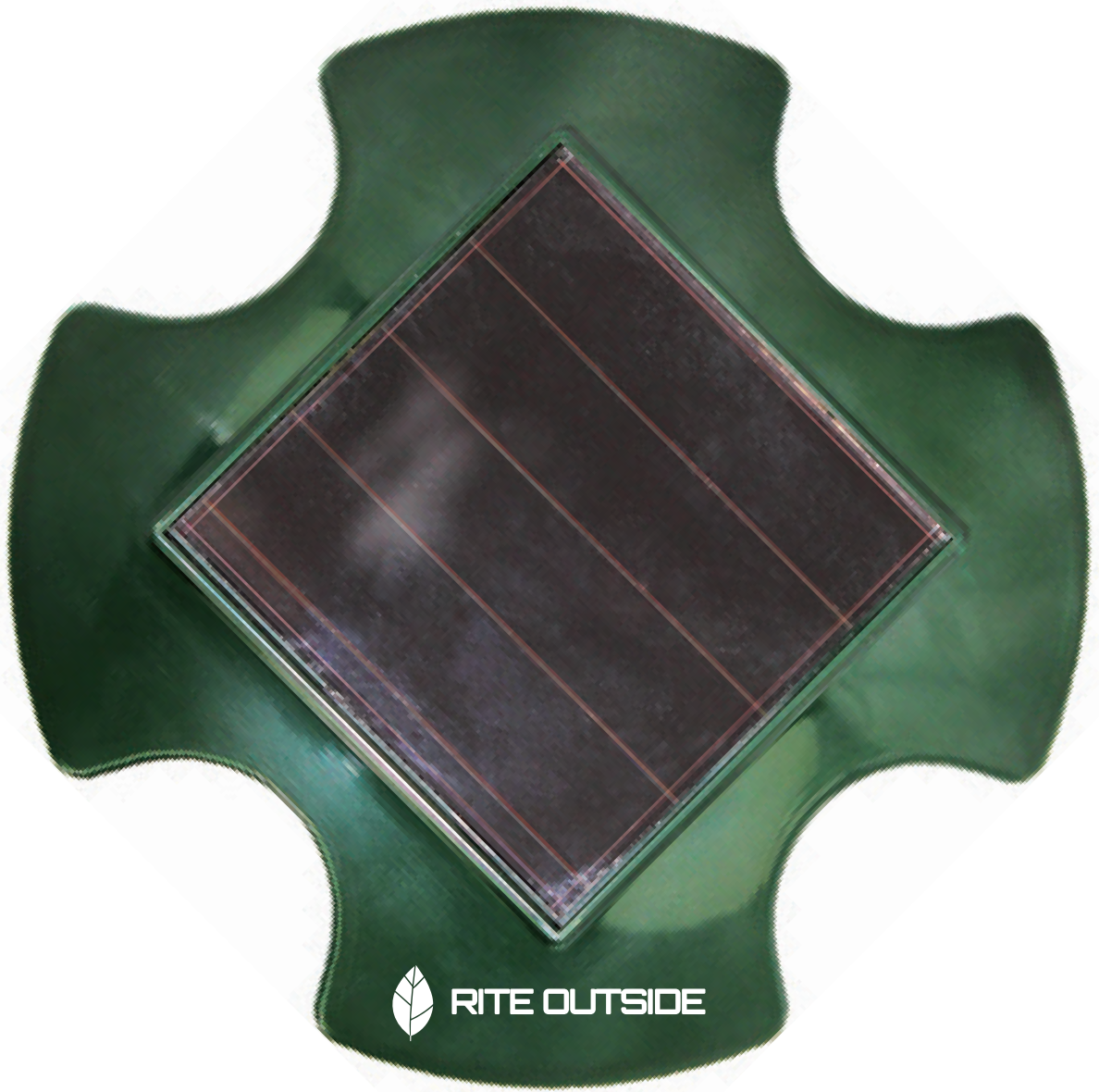

RITE OUTSIDE